

20.11.2015

PROIECT

HOTĂRÂREA Nr. ____/____.____.2015
privind aprobarea achiziționării în sistem leasing pe o perioadă de 60 de luni prin
Porche Leasing Romania IFN S.A. de către Municipiul Pășcani a unui AUTOGRADER
HBS NOBAS BG160TA4 MAN

Consiliul Local al Municipiului Pășcani, județul Iași;

Având în vedere Expunerea de motive înregistrată sub nr. 21822/20.11.2015, întocmită de Primarul Municipiului Pășcani, în calitate de inițiator al proiectului de hotărâre;

Având în vedere Raportul înregistrat sub nr. 21823/20.11.2015, întocmit de Direcția Economică și Gospodăria Comunală din cadrul aparatului de specialitate al Primarului Municipiului Pășcani;

Având în vedere oferta de leasing financiar înregistrată sub nr. 2174/19.11.2015;

Având în vedere dispozițiile Legii nr. 215/2001 privind administrația publică locală, republicată, cu modificările și completările ulterioare;

Având în vedere prevederile art. 67 din Legea nr. 273/2006 privind finanțele publice locale, actualizată;

Având în vedere Rapoartele de avizare ale următoarelor comisii de specialitate din cadrul Consiliului Local al Municipiului Pășcani :

- *Comisia de prognoze economico-sociale, buget, finanțe, industrie, agricultură, silvicultură, prestări servicii, comerț și IMM-uri, programe europene, atragere de fonduri structurale și relații externe, înregistrat sub nr. ____/____.____.2015;*

- *Comisia juridică, ordine publică, drepturile omului și libertăți cetățenești, înregistrat sub nr. ____/____.____.2015;*

În temeiul art. 45 alin. (1) din Legea nr. 215/2001 privind administrația publică locală, republicată, cu modificările și completările ulterioare,

HOTĂRĂȘTE:

Art.1. Se aproba achiziționarea în sistem leasing pe o perioadă de 60 de luni prin Porche Leasing Romania IFN S.A. de către Municipiul Pășcani a unui autograder HBS NOBAS BG160TA4 MAN.

Art. 2. Achiziția autocamionului prevăzut la art. 1 se va face exclusiv din veniturile bugetului local al Municipiului Pășcani, conform ofertei de leasing, anexa la prezenta hotărâre.

Art.3. Primarul municipiului Pășcani prin aparatul de specialitate va duce la îndeplinire prevederile prezentei hotărâri.

Art.4. Serviciul administrație publică locală va comunica în copie prezenta hotărâre:

- Instituției Prefectului județului Iași;
- Primarului Municipiului Pașcani;
- Direcției Economice;
- Serviciului Gospodarie Comunala Pașcani;

Initiator,

PRIMARUL MUNICIPIULUI PASCANI,
Ing. DUMITRU PANTAZI



PREȘEDINTE DE ȘEDINȚĂ

CONSILIER LOCAL,

CONTRASEMNEAZĂ
PENTRU LEGALITATE

SECRETARUL MUNICIPIULUI
PASCANI,
Cons. jr. ALINA SANDU

ROMANIA
JUDETUL IASI
UNITAREA ADMINISTRATIV TERITORIALA MUNICIPIUL PASCANI
PRIMARUL MUNICIPIULUI PASCANI

Nr. 21822/20.11:2015

- EXPUNERE DE MOTIVE -

Referitor la: Proiectul de Hotarare privind aprobarea achizitionarii in sistem leasing pe o perioada de 60 de luni prin Porche Leasing Romania IFN S.A. de catre Municipiul Pascani a unui AUTOGRADER HBS NOBAS BG160TA4 MAN

Avand in vedere dispozitiile Legea nr. 215/2001 privind administratia publica locala, republicata, cu modificarile si completarile ulterioare;

Avand in vedere prevederile art. 67 din Legea nr. 273/2006 privind finantele publice locale, actualizata;

Avand in vedere necesitatea innoirii parcului auto al Serviciului Gospodarie Comunala din cadrul Primariei Municipiului Pascani si a rezolvarii problemelor curente de intretinere a drumurilor, atat pe timp de vara, cat si pe timp de iarna, in municipiul Pascani;

Avand in vedere prevederile Legii nr. 273/2006 privind finantele publice locale, actualizata;

Fata de considerentele sus-mentionate propun spre analiza si aprobare Consiliului local al municipiului Pascani proiectul de hotarare privind aprobarea achizitionarii in sistem leasing pe o perioada de 60 de luni prin Porche Leasing Romania IFN S.A. de catre Municipiul Pascani a unui AUTOGRADER HBS NOBAS BG160TA4 MAN.

PRIMARUL MUNICIPIULUI PASCANI
Ing. DUMITRU PANTAZI

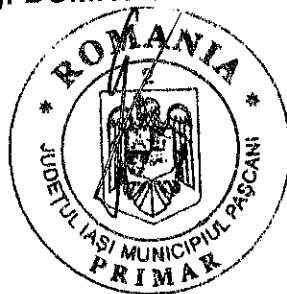

ROMANIA
JUDEȚUL IAȘI
PASCANI,
MUNICIPIUL PASCANI

Nr. 21823/20.11.2015

SE APROBA,
PRIMARUL MUNICIPIULUI

Ing. DUMITRU PANTAZI

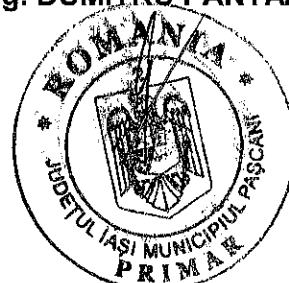

- RAPORT -

Referitor la: Proiectul de Hotarare privind aprobarea achizitionarii in sistem leasing pe o perioada de 60 de luni prin Porche Leasing Romania IFN S.A. de catre Municipiul Pâșcani a unui AUTOGRADER HBS NOBAS BG160TA4 MAN

Având în vedere Expunerea de motive înregistrată sub nr. 21822/20.11.2015, întocmită de Primarul Municipiului Pâșcani, în calitate de initiator al proiectului de hotărâre;

Având în vedere prevederile art. 36 alin. (2) lit. d), conform cărui consiliul local îndeplinește atribuții privind gestionarea serviciilor furnizate către cetățeni;

Având în vedere prevederile art. 67 alin. (1) lit. a) din Legea nr. 273/2006 privind finanțele publice locale, actualizată, potrivit căreia "*Finanțarea instituțiilor publice - (1) Finanțarea cheltuielilor curente și de capital ale instituțiilor publice se asigură astfel: a) integral din bugetul local*";

Având în vedere oferta de leasing financiar înregistrată sub nr. 21711/19.11.2015, înaintată de Porche Leasing Romania INF S.A.

Fata de considerentele expuse anterior Direcția Economică și Serviciul Gospodărie Comunală din cadrul aparatului de specialitate al Primarului Municipiului Pâșcani, avizează favorabil **Proiectul de Hotarare privind aprobarea achizitionarii in sistem leasing pe o perioada de 60 de luni prin Porche Leasing Romania IFN S.A. de catre Municipiul Pâșcani a unui AUTOGRADER HBS NOBAS BG160TA4 MAN.**

DIRECTIA ECONOMICA,
Ec. LABONTU ANGELICA

SERVICIUL GOSPODARIE COMUNALA
PASCANI

Ing. STEFAN POPA

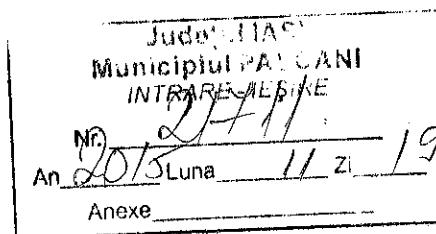
ANEXA 2 LA CONTRACTUL DE LEASING**OFERTA DE LEASING FINANCIAR
NUMAI CU SCOP INFORMATIV!**CLIENT **MUNICIPIUL PASCANI**Obiectul Leasingului : **AUTOGREDER HBS NOBAS BG160TA4****CONDITII FINANTARE**

Pret DDP		233.570,12	EUR
Pret de achizitie unitar		188.363,00	EUR
Prima plata	25,00 %	47.090,75	EUR
Durata leasingului		60	LUNI
Taxa de administrare (% din vol. finantat)	1,70 %	2.401,63	EUR
Comision analiza dosar		150,00	EUR
Km / an		25.000	KM
Valoare Reziduala	1,00 %	1.883,63	EUR
Tarif pe Km parcurs peste numarul maxim inclus in oferta de leasing		0.4182	EUR/Km

RATA DE LEASING LUNARA	2.690,27	EUR
ASIGURARE CASCO OBLIGATORIE LUNARA	214,11	EUR
RATA DE LEASING LUNARA INCLUSIV ASIGURAREA CASCO OBLIGATORIE	2.904,38	EUR

Total rate platibile catre Porsche Leasing	161.416,20	EUR
Total asigurare casco obligatorie	12.846,60	EUR

Tarif dobanda	NLXXXXFE	Dobanda fixa	5,79 %
Tarif asigurare	CASCO UNIQA		
DAE	6,69 %		

CONDITII DE ASIGURARE

Asigurator	UNIQA ASIGURARI SA
Cota de asigurare	1,10 %

Am luat la cunostinta ca pot vizualiza/descarca Conditile de asigurare de pe site-ul www.porschebank.ro.
Aceste valori nu includ TVA.

29.10.2015

PAG. 1

Porsche Leasing România IFN SA
B-dul Pipera nr. 2, clădirea Porsche Bank,
077100, Voluntari, județul Ilfov

1234567890
CUI 12345678
Capital social 11.800.000 RON
Operează de date cu caracter personal nr. 890
RO-PUR-42-110182
RS-PUR-42-110632
Tel. +40 21 208 28 00
Fax +40 21 208 28 05
E-mail: office@porschebank.ro
www.porschebank.ro

Va informam ca rata dvs. de leasing (fara TVA) exprimata in RON la cursul de la data prezentei oferte este de: **12.040,03 RON**. Valoarea simulata in RON a ratei, in conformitate cu prevederile Regulamentului 17/2012 ar putea ajunge la: **16.314,25 RON**.

Intrucat in cazul autovehiculelor achitarea "Timbrului de mediu" / a sumei datorate pentru emisiile provenite de la autovehicule este o obligatie legala, Partile stabilesc de comun acord ca suportarea acestei taxe este in sarcina Utilizatorului. Valoarea Timbrului de mediu datorata Locatorului, de catre Utilizator va fi calculata conform prevederilor OUG 9/2013 privind timbrul de mediu pentru autovehicule si potrivit normelor metodologice de aplicare a acestei prevederi legale. In consecinta, contravaloarea in LEI (RON) a "Timbrului de mediu" va fi platita la bugetul de stat de catre Porsche Leasing Romania IFN SA si va fi refacturata Utilizatorului cu TVA aferenta, odata cu prima rata de

Asigurarea RCA nu este cuprinsa in aceasta calculatie. Tichetul RCA va fi emis anual de catre Porsche Broker de Asigurare, iar costul sau va fi suportat de catre Utilizator.

Aceasta este o **oferta fara obligatii** care necesita aprobarea Porsche Leasing Romania IFN SA.

Pentru informatii suplimentare va rugam sa va adresati Dealerului dumneavoastra.

Prin semnatura, clientul accepta conditiile mai sus mentionate si solicita incheierea Contractului.

Data 29.10.2015

Semnatura client/ stampila

Vanzator MUNTEANU CLAUDIA

29.10.2015

PAG. 2

Porsche Leasing Romania IFN SA
B-dul Pipera nr. 2, clădirea Porsche Bank,
077100, Voluntari, Judetul Ilfov.

J23436/2004

CUI 12034199

Capital social 11.500.000 RON

Operator de date cu caracter personal nr. 990

RG-PUR-62-110182

RS-PUR-42-110032

Tel.: +40 21 208 26 00

Fax: +40 21 208 26 08

E-mail: office@porschebank.ro

www.porschebank.ro

SCADENTAR 00002796
ANEXA 3 LA CONTRACTUL DE LEASING

Data: 29.10.2015

Utilizator: **MUNICIPIUL PASCANI**
 Obiectul leasingului: **AUTOGREDER HBS NOBAS BG160TA4**
 Perioada leasingului: **60 luni**
 Pret de achizitie (CIP): 188.363,00 EUR
 Pret DDP: 233.570,12 EUR
 Prima plata: **25,00 %** 47.090,75 EUR
 Valoare reziduala **1,00 %** 1.883,63 EUR
 Asigurare obligatorie: 214,11 EUR
 Volum finantat: 141.272,25 EUR
 Taxa administrare credit **1,70 % din vol. finantat** 2.401,63 EUR
 Comision analiza dosar 150,00 EUR
 Prima plata + taxa administrare + comision analiza dosar fara TVA 49.642,38 EUR

Nr. Rata	Capital Rata	Dobanda	Total Rata	Asigurare Casco	Total Plati	Total Plati Incl. TVA
1	2.008.63 EUR	681.64 EUR	2.690.27 EUR	214.11 EUR	2.904.38 EUR	3.550.04 EUR
2	2.018.32 EUR	671.95 EUR	2.690.27 EUR	214.11 EUR	2.904.38 EUR	3.550.04 EUR
3	2.028.06 EUR	662.21 EUR	2.690.27 EUR	214.11 EUR	2.904.38 EUR	3.550.04 EUR
4	2.037.85 EUR	652.42 EUR	2.690.27 EUR	214.11 EUR	2.904.38 EUR	3.550.04 EUR
5	2.047.68 EUR	642.59 EUR	2.690.27 EUR	214.11 EUR	2.904.38 EUR	3.550.04 EUR
6	2.057.56 EUR	632.71 EUR	2.690.27 EUR	214.11 EUR	2.904.38 EUR	3.550.04 EUR
7	2.067.49 EUR	622.78 EUR	2.690.27 EUR	214.11 EUR	2.904.38 EUR	3.550.04 EUR
8	2.077.46 EUR	612.81 EUR	2.690.27 EUR	214.11 EUR	2.904.38 EUR	3.550.04 EUR
9	2.087.49 EUR	602.78 EUR	2.690.27 EUR	214.11 EUR	2.904.38 EUR	3.550.04 EUR
10	2.097.56 EUR	592.71 EUR	2.690.27 EUR	214.11 EUR	2.904.38 EUR	3.550.04 EUR
11	2.107.68 EUR	582.59 EUR	2.690.27 EUR	214.11 EUR	2.904.38 EUR	3.550.04 EUR
12	2.117.85 EUR	572.42 EUR	2.690.27 EUR	214.11 EUR	2.904.38 EUR	3.550.04 EUR
13	2.128.07 EUR	562.20 EUR	2.690.27 EUR	214.11 EUR	2.904.38 EUR	3.550.04 EUR
14	2.138.34 EUR	551.93 EUR	2.690.27 EUR	214.11 EUR	2.904.38 EUR	3.550.04 EUR
15	2.148.65 EUR	541.62 EUR	2.690.27 EUR	214.11 EUR	2.904.38 EUR	3.550.04 EUR
16	2.159.02 EUR	531.25 EUR	2.690.27 EUR	214.11 EUR	2.904.38 EUR	3.550.04 EUR
17	2.169.44 EUR	520.83 EUR	2.690.27 EUR	214.11 EUR	2.904.38 EUR	3.550.04 EUR
18	2.179.91 EUR	510.36 EUR	2.690.27 EUR	214.11 EUR	2.904.38 EUR	3.550.04 EUR
19	2.190.42 EUR	499.85 EUR	2.690.27 EUR	214.11 EUR	2.904.38 EUR	3.550.04 EUR
20	2.200.99 EUR	489.28 EUR	2.690.27 EUR	214.11 EUR	2.904.38 EUR	3.550.04 EUR
21	2.211.61 EUR	478.66 EUR	2.690.27 EUR	214.11 EUR	2.904.38 EUR	3.550.04 EUR
22	2.222.28 EUR	467.99 EUR	2.690.27 EUR	214.11 EUR	2.904.38 EUR	3.550.04 EUR
23	2.233.01 EUR	457.26 EUR	2.690.27 EUR	214.11 EUR	2.904.38 EUR	3.550.04 EUR
24	2.243.78 EUR	446.49 EUR	2.690.27 EUR	214.11 EUR	2.904.38 EUR	3.550.04 EUR
25	2.254.61 EUR	435.66 EUR	2.690.27 EUR	214.11 EUR	2.904.38 EUR	3.550.04 EUR

29.10.2015

PAG. 1

Porsche Leasing Romania IFN SA
 B-dul Pipera nr. 2, cladirea Porsche Bank,
 077150, Voluntari, Judetul Ilfov

J224692004

CUI 12004109

Capital social 11.800.000 RON

Expansor de date cu caracter personal nr. 990

RS-PUR-42-110192

RS-PUR-42-110932

Tel. +40 21 208 26 00

Fax +40 21 208 26 05

E-mail: office@porschebank.ro

www.porschebank.ro

SCADENTAR 00002796
ANEXA 3 LA CONTRACTUL DE LEASING

Data: 29.10.2015

Utilizator:	MUNICIPIUL PASCANI		
Obiectul leasingului:	AUTOGREDER HBS NOBAS BG160TA4		
Perioada leasingului:	60 luni		
Pret de achizitie (CIP):			188.363,00 EUR
Pret DDP:			233.570,12 EUR
Prima plata:	25,00 %		47.090,75 EUR
Valoare reziduala	1,00 %		1.883,63 EUR
Asigurare obligatorie:			214,11 EUR
Volu finantat:			141.272,25 EUR
Taxa administrare credit	1,70 % din vol. finantat		2.401,63 EUR
Comision analiza dosar			150,00 EUR
Prima plata + taxa administrare + comision analiza dosar fara TVA			49.642,38 EUR

Nr. Rata	Capital Rata	Dobanda	Total Rata	Asigurare Casco	Total Plati	Total Plati Incl. TVA
26	2.265.48 EUR	424.79 EUR	2.690.27 EUR	214.11 EUR	2.904.38 EUR	3.550.04 EUR
27	2.276.42 EUR	413.85 EUR	2.690.27 EUR	214.11 EUR	2.904.38 EUR	3.550.04 EUR
28	2.287.40 EUR	402.87 EUR	2.690.27 EUR	214.11 EUR	2.904.38 EUR	3.550.04 EUR
29	2.298.44 EUR	391.83 EUR	2.690.27 EUR	214.11 EUR	2.904.38 EUR	3.550.04 EUR
30	2.309.53 EUR	380.74 EUR	2.690.27 EUR	214.11 EUR	2.904.38 EUR	3.550.04 EUR
31	2.320.67 EUR	369.60 EUR	2.690.27 EUR	214.11 EUR	2.904.38 EUR	3.550.04 EUR
32	2.331.87 EUR	358.40 EUR	2.690.27 EUR	214.11 EUR	2.904.38 EUR	3.550.04 EUR
33	2.343.12 EUR	347.15 EUR	2.690.27 EUR	214.11 EUR	2.904.38 EUR	3.550.04 EUR
34	2.354.42 EUR	335.85 EUR	2.690.27 EUR	214.11 EUR	2.904.38 EUR	3.550.04 EUR
35	2.365.78 EUR	324.49 EUR	2.690.27 EUR	214.11 EUR	2.904.38 EUR	3.550.04 EUR
36	2.377.20 EUR	313.07 EUR	2.690.27 EUR	214.11 EUR	2.904.38 EUR	3.550.04 EUR
37	2.388.67 EUR	301.60 EUR	2.690.27 EUR	214.11 EUR	2.904.38 EUR	3.550.04 EUR
38	2.400.19 EUR	290.08 EUR	2.690.27 EUR	214.11 EUR	2.904.38 EUR	3.550.04 EUR
39	2.411.77 EUR	278.50 EUR	2.690.27 EUR	214.11 EUR	2.904.38 EUR	3.550.04 EUR
40	2.423.41 EUR	266.86 EUR	2.690.27 EUR	214.11 EUR	2.904.38 EUR	3.550.04 EUR
41	2.435.10 EUR	255.17 EUR	2.690.27 EUR	214.11 EUR	2.904.38 EUR	3.550.04 EUR
42	2.446.85 EUR	243.42 EUR	2.690.27 EUR	214.11 EUR	2.904.38 EUR	3.550.04 EUR
43	2.458.66 EUR	231.61 EUR	2.690.27 EUR	214.11 EUR	2.904.38 EUR	3.550.04 EUR
44	2.470.52 EUR	219.75 EUR	2.690.27 EUR	214.11 EUR	2.904.38 EUR	3.550.04 EUR
45	2.482.44 EUR	207.83 EUR	2.690.27 EUR	214.11 EUR	2.904.38 EUR	3.550.04 EUR
46	2.494.42 EUR	195.85 EUR	2.690.27 EUR	214.11 EUR	2.904.38 EUR	3.550.04 EUR
47	2.506.46 EUR	183.81 EUR	2.690.27 EUR	214.11 EUR	2.904.38 EUR	3.550.04 EUR
48	2.518.55 EUR	171.72 EUR	2.690.27 EUR	214.11 EUR	2.904.38 EUR	3.550.04 EUR
49	2.530.70 EUR	159.57 EUR	2.690.27 EUR	214.11 EUR	2.904.38 EUR	3.550.04 EUR
50	2.542.91 EUR	147.36 EUR	2.690.27 EUR	214.11 EUR	2.904.38 EUR	3.550.04 EUR

29.10.2015

PAG. 2

Porsche Leasing Romania IFN SA
B-dul Pipera nr. 2, cladirea Porsche Bank,
077100, Voluntari, Judetul Ilfov

RO24092004
CUI 12004199
Capital social 11.000.000 RON
Operator de date cu caracter personal nr. 980
RO-PUR-02-110182
RO-PUR-02-110002

Tel. +40 21 208 26 00
Fax +40 21 208 26 05
E-mail: office@porschebank.ro
www.porschebank.ro

Member of Porsche Bank Group

SCADENTAR 00002796
ANEXA 3 LA CONTRACTUL DE LEASING

Data: 29.10.2015

Utilizator: **MUNICIPIUL PASCANI**
 Obiectul leasingului: **AUTOGREDER HBS NOBAS BG160TA4**
 Perioada leasingului: **60 luni**
 Pret de achizitie (CIP): 188.363,00 EUR
 Pret DDP: 233.570,12 EUR
 Prima plata: **25,00 %** 47.090,75 EUR
 Valoare reziduala **1,00 %** 1.883,63 EUR
 Asigurare obligatorie: 214,11 EUR
 Volum finantat: 141.272,25 EUR
 Taxa administrare credit **1,70 % din vol. finantat** 2.401,63 EUR
 Comision analiza dosar 150,00 EUR
 Prima plata + taxa administrare + comision analiza dosar fara TVA 49.642,38 EUR

Nr. Rata	Capital Rata	Dobanda	Total Rata	Asigurare Casco	Total Plati	Total Plati Incl. TVA
51	2.555.18 EUR	135.09 EUR	2.690.27 EUR	214.11 EUR	2.904.38 EUR	3.550.04 EUR
52	2.567.51 EUR	122.76 EUR	2.690.27 EUR	214.11 EUR	2.904.38 EUR	3.550.04 EUR
53	2.579.90 EUR	110.37 EUR	2.690.27 EUR	214.11 EUR	2.904.38 EUR	3.550.04 EUR
54	2.592.35 EUR	97.92 EUR	2.690.27 EUR	214.11 EUR	2.904.38 EUR	3.550.04 EUR
55	2.604.86 EUR	85.41 EUR	2.690.27 EUR	214.11 EUR	2.904.38 EUR	3.550.04 EUR
56	2.617.42 EUR	72.85 EUR	2.690.27 EUR	214.11 EUR	2.904.38 EUR	3.550.04 EUR
57	2.630.05 EUR	60.22 EUR	2.690.27 EUR	214.11 EUR	2.904.38 EUR	3.550.04 EUR
58	2.642.74 EUR	47.53 EUR	2.690.27 EUR	214.11 EUR	2.904.38 EUR	3.550.04 EUR
59	2.655.49 EUR	34.78 EUR	2.690.27 EUR	214.11 EUR	2.904.38 EUR	3.550.04 EUR
60	2.668.38 EUR	21.89 EUR	2.690.27 EUR	214.11 EUR	2.904.38 EUR	3.550.04 EUR
Total	139.388,62 EUR	22.027,58 EUR	161.416,20 EUR	12.846,60 EUR	174.262,80 EUR	213.002,69 EUR

TOTAL PLATI 225.788,81 EUR 276.894,94 EUR
 (inclusiv prima plata, taxa adm., comision analiza si valoarea reziduala)

Tarif dobanda NLXXXXFE Dobanda fixa: : 5,79 %
 Asigurator UNIQA ASIGURARI SA
 Tarif asigurare CASCO UNIQA 1,10
DAE 6,69 %

29.10.2015

PAG. 3

Handwritten notes:
10.11.2015
10.11.2015
10.11.2015



Handwritten notes on a sign:
10.11.2015
10.11.2015
10.11.2015



Motor Grader

BG 160 T-4 (6x4) / BG 160 TA-4 (6x6)

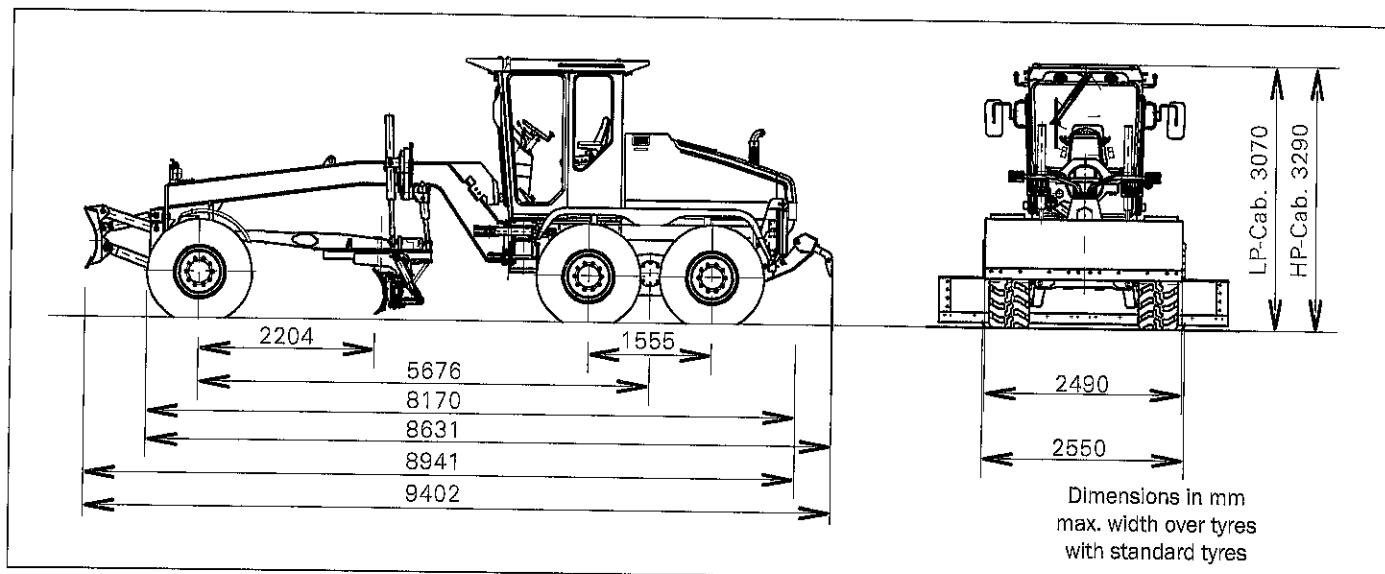

Engine Data

Make/Model	CUMMINS/diesel engine
Type	4 cycle, direct injection, turbo charged, water-cooled, intercooled
Rated net horsepower (SAE J 1995) at 2200 rpm,	119 kW/162 HP
No. of cylinder	in line 6
Bore & stroke	107 x 124 mm
Displacement	6.7 litres

Engine equipped with a dual element, dry type air cleaner with dust ejector. 24 V starting and electrical system. 70 Amp alternator and 24 V starter with 3.7 kW (5.0 HP). 2 batteries 74 Ah each.

Speeds (all wheel drive and rear axle drive systems)

Forward	km/h
1.	4.3
2.	6.7
3.	11.0
4.	17.2
5.	25.0
6.	40.0
Reverse	km/h
1.	4.3
2.	11.0
3.	25.0

Acoustic back up alarm in reverse driving



Operating weight

Total weight	approx. 16000 kg
On rear wheels	approx. 11200 kg
On front wheels	approx. 4800 kg

Weights shown include cab, all operating fluids, 4-teeth rear ripper, front dozer blade



Rear Axle

Oscillating tandem axle with axle insert.
Operator controlled wet multiple disc lock/unlock differential.
Multi-disc brakes in all four wheel hubs.
Parking brake at powershift transmission.



Tandems

Drive via roller chains.	
Torsion-proof box section.	
Height	550 mm
Width	184 mm
Thickness of walls	20 mm
Wheel base	1542 mm
Oscillation	± 15°
Ground clearance	435 mm



All wheel drive system

Hydrodynamic rear axle drive with 6-speed Ergopower transmission and torque converter (make ZF 6 WG) with freely selectable micro-processor controlled hydrostatic front axle drive. Power train is controlled appropriate to tyre traction.



Rear axle drive system

Hydrodynamic rear axle drive with 6-speed Ergopower transmission (make ZF 6 WG) and torque converter.



Wheels & Tyres



Brakes

Service brake

Dual circuit, power-assisted, multiple-disc oil-bath type, effective on four wheels. Includes reserve power and operator warning system.

Parking brake

Independent electrically operated, acting on power shift, hydraulic spring accumulated single disc type.



Front Axle

2 types are available

Oscillation	15° up and down
Steering angle	45°
Wheel lean	±17°
Ground clearance	546 mm

Non driven with wheel lean (T version)

Stable welded steel beam with wheel lean.

Driven with wheel lean (TA version)

Stable welded steel beam with wheel lean and radial piston engines in wheel hubs, pulling power on surface conditions. Electronically adjustable (infinitely variable), possibility to fit in the hydraulic differential lock.



Steering

Hydraulic power steering

Minimum turning radius without dozer blade	6900 mm
Minimum turning radius with dozer blade	7650 mm
Steering angle	45°



Frame

Front and rear frame sections connected with an adjustment-free articulated pin.

Front: Fully welded box section

Minimum dimensions of box section	270 x 270 mm
Plate thickness	20 mm

Rear: Fully welded box section

Dimensions (solid main bars)	250 x 80 mm
Hydraulic articulated frame steering (left & right)	30°



Circle (closed version)

Hardened teeth, machine-cut on inside of circle for maximum strength and minimum wear. The circle is held positively in place by an adjustment-free roller bearing.

Circle diameter	1348 mm
Tool width	78 mm
Height	130 mm



Circle drive

Hydraulically driven worm gear transmission. Circle drive system fully protected against impact damage by an overload clutch.



Drawbar

Y-shaped fully welded construction.
Dimensions (solid sections)

30 x 175 mm



Moldboard (Standard)

Moldboard (1.2 ft) 3660 x 580 x 20 mm
Blade material High carbon steel
Blade pull (at a friction factor of 0,8)

BG 160 T-4 80 kN
BG 160 TA-4 105 kN



Blade Range

Reach outside tyres without articulation (RH&LH) blade resting on levelled surface	2220 mm/1780 mm
Reach outside tyres with articulation (RH&LH), blade resting on levelled surface	3050 mm/2610 mm
Blade side shift	1250 mm
Blade tilt range	38°-78°
Bank sloping angle (RH&LH)	90°
Lift above ground	480 mm
Cut below ground	520 mm
Distance blade/front axle	2204 mm

All blade movements and positions can be controlled from the operator's seat.



Operator's Platform

Dimensions

Width	1150 mm
Depth	1400 mm

Available with various options as listed under "Optional equipment", moldboard control acc. to EURO-standard.



Capacities

Fuel tank	310.0 litres
Hydraulic oil tank	170.0 litres
Engine oil	18.0 litres
Ergopower transmission	34.0 litres
Axle drive front (BG 160 TA-4)	8.3 litres
Axle drive rear	13.5 litres
Planetary gears front (BG 160 TA-4)	3.6 litres
Planetary gears and brakes	16.0 litres
Tandem case (2 x 21 litres)	42.0 litres
Circle drive	6.0 litres
Coolant	33.0 litres



Light Equipment

2 headlights front, 2 direction indicator lights each (including warning signal flasher) front and rear and additional 2 at cab, 12/28/2015 9:16 AM



Load-Sensing Hydraulics

The control valves of the working hydraulics may be actuated at a time and independent of each other. The load-sensing pump (axial piston pump) discharges only the required quantity of oil if a control valve is actuated. When hydraulic power is not required system pressure is only 24 bar and this low standby pressure improves fuel-efficiency and reduces heat generation.

Lock valves and brake valves prevent a cylinder drift under load.

Operating pressure	205 bar
Oil flow, max.	99l/min



Optional Equipment

Standard-Cab, tiltable

Integrated ROPS/FOPS cab mounted on isolators to limit vibration and noise entering the cab. Excellent all-round visibility. Roomy and comfortable. Adjustable steering pedestal with EURO control lever arrangement. Interior of cab fully lined, floor covering. Tinted safety glass windows, sliding doors left and right with lockable intermediate positions, fresh air heating with pre-filter, air circulation. Adjustable, mechanical spring mounted driver's seat with safety belt. One inside mirror and two folding outside mirrors.

Front window washer.

Wipers front and rear.

Blinds front and rear.

Height / Width / Depth 1980 / 1470 / 1700 mm

Low-profile cab, tiltable

Height / Width / Depth 1760 / 1470 / 1700 mm

NAIS control panel (rods)

EP control panel (Joystick controls)

Air-condition for cab

Heatable rear view mirrors

Auxiliary heating

Beacon (orange)

Air-cushioned driver's seat

Recording speedometer

Cooling box

Stereo radio with CD-Player

Sliding side windows

Protective grids for lights and cabin

Moldboard (14 ft) 4267 x 580 x 20 mm

Cover plate for upper guide rail of moldboard

Adjustable moldboard corner shoes, left or right

Moldboard extension, left or right (1 ft) 305 mm

Float position for both moldboard lift cylinders

Electric fuel pump with automatic switch-off

Towing device, tiltable

Wheels and tyres

Tyre size 14.00-24 diagonal
Rim size 10.00 x 24

Tyre size 405/70 R24 radial
Rim size 13.00 x 24

Tyre size 17.5 R25 radial
Rim size 14.00 x 25/1.3

Other types on request.

Front dozer blade with position indicator, parallel guided

Width / Height 2490 x 703 mm

Cut below ground 250 mm

Lift above ground 605 mm

Weight 691 kg

V-scariër between front axle and moldboard, 9 teeth

Ripping width 1060 mm

Ripping depth 240 mm

Lift above ground 280 mm

Weight 850 kg

Rear ripper with depth indicator, 4 teeth (max. 7)

Ripping width 2120 mm

Ripping depth 285 mm

Lift above ground 580 mm

Weight 610 kg

Rear ripper with depth indicator, medium heavy, 4 teeth (max. 7)

Ripping width 2120 mm

Ripping depth 420 mm

Lift above ground 560 mm

Weight 804 kg

Push-Pull block, in front

556 kg

Front dozer blade, articulated

Mudguards

on front wheels

Mudguards

on rear wheels

Protective cover for powershift transmission

Biological Oil in hydraulic system

Ergopower transmission (ZF 8 WG) with torque converter and lock-up clutch (speeds 8/4)

Fuel tank pump with automatic switch-off

Special paint

Tool kit, wheel chocks, warning triangle, Fire extinguisher, First aid kit etc.

Automatic blade control

Various automatic laser or ultrasonic controlled blade systems

CE certified

Speed limitation at 25 km/h possible

GP Papenburg International GmbH



GP Günter Papenburg AG

headquarter

Ruhisdorfer Straße 100 · 14513 Teltow · Germany

Tel: ++49 (0) 3328 456-412 · Fax: ++49 (0) 3328 456-251

E-Mail: vertrieb-international@gp.ag · www.gp.ag



Rothenburgstraße 20 · 99734 Nordhausen · Germany

Tel: ++49 (0) 3631 695-125 · Fax: ++49 (0) 3631 695-152

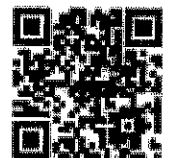

Actual data are subject to change.

10/28/2011 11:16 AM

K.S.M. Lead SRL
 Complex Schneid, Calea Fagarasului nr. 59,
 Stand 69, Braşov, România
 RO 18481861, JO8/628/2006
 E-mail: office@ksm.ro
 Tel: +40 371 13 86 87
 Fax: +40 372 001 322 / +40 268 708 969



CLIENT	
In att.	Dn-lui Pantazi Dumitru
Companie	Primaria Pascani
Oras	Pascani
Contact	

Datele ofertei	
Nr. of.	OF1510271
Data	27/10/15
Reprezentat	Marius Tudose
Contact	0734522522 office@ksm.ro

OFERTA PENTRU :	AUTOTOGREDER HBM NOBAS BG160TA4 6x6 -NOU-
------------------------	--------------------------------------------------

MODEL: BG 160 TA4.**CONFIGURATIE MODEL DE BAZA:**

Putere motor	162 CP
Greutate operationala maxima	15000 kg
Dimensiuni lama mediana	3660x580x20 mm
Fora de rupere lama mediana (coeficient de frecare 0.8)	105 kN
Viteza maxima de deplasare inainte / inapoi	40 /25 km/h
Garda la sol fata / spate	546 / 435 mm
Raza minima de intoarcere fara/cu lama frontala	6900/7650 mm
Rezervor motorina rabatabil	310 l

MOTOR TERMIC

Cummins QSB 6,7 , injectie directa, turbo Tier III

Putere (CP)	162
Numa cilindri	6
Capacitate cilindrica (cm3)	6700

TRANSMISIE

Sistem de deplasare cu tractiune 6x6

Transmisie punte spate HIDRODINAMICA controlata electronic functie de aderenta ZF

ERGOPOWER

Oscilatie punte spate	+/- 15 grade
Garda la sol punte spate	435 mm
Transmisie punte fata HIDROSTATICA controlata electronic functie de aderenta Bosch Rexroth	
Oscilatie punte fata	+/- 15 grade
Garda la sol punte fata	546 mm
Inclinare hidraulica a rotilor de pe axul frontal	+/- 17 grade
Numar viteze inainte/inapoi	6/3
Viteza maxima de deplasare inainte / inapoi	40 /25 - km/h
Pneuri Radiale	455/70 R24

SISTEMUL DE FRANARE

FRANA DE SERVICIU pe 4 roti cu dublu circuit, tip multi-disc in baie de ulei, cu amplificator, rezerva de putere si sistem de avertizare

FRANA DE MANA Independenta, cu actionare electrica pe transmisie

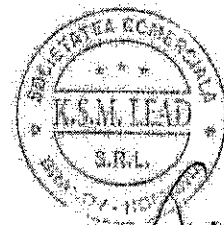

K.S.M. Lead SRL
 Complex:Schneid, Calea Fagarasului nr. 59,
 Stand 69, Brasov, Romania
 RO 18481861, 108/628/2006
 E-mail: office@ksm.ro
 Tel: +40 371 13.86.37
 Fax: +40 372 004 922 / +40 268 708 969



SISTEM HIDRAULIC

Sistem hidrolic cu auto ajustare a debitului functie de incarcare Load-sensing

Pompa hidrolică cu pistone axiale

Debit maxim pompa

99l/min.

Presiune maxima de lucru

205 bari

CABINA

Cabina cu protectie ROPS/FOPS, rabatabila, cu AER.CONDITIONAT si incalzire

Scaun cu amortizare multi-ajustabil si tetiera

Sistem de avertizare pentru deplasare inapoi

Sistem complet de iluminare si semnalizare (15 puncte de iluminat si semnalizat)

Inaltime de transport peste cabina

3290 mm

Girofar

LAMA MEDIANA

Dimensiuni lama mediana

3660x580x20 mm

Sistem de deplasare laterala a lamel mediane

1250 mm

Unghi inclinare lama

38 grade - 78 grade

Inaltime maxima de ridicare a lamel

480 mm

Adancime maxima de patrundere

520 mm

Material - otel de inalta calitate cu continut ridicat de carbon

Fora de rupere lama mediana (coeficient de frecare 0.8)

105 kN

LAMA BULDOZER

Lama frontala cu indicator de pozitie, dimensiuni 2490 x 703 mm, adancime maxima de patrundere 250 mm, Inaltime maxima de ridicare a lamei 650 mm, greutate 691 kg

SCARIFICATOR

Scarificator STANDARD, spate, 4 dinti (max. 7 dinti) cu indicator de penetrare, latime 2120 mm, adancime maxima de penetrare 285 mm, Inaltime maxima de ridicare 580 mm, greutate 610 kg

DOTARI SUPLIMENTARE INCLUSE IN PRET

1. Corpăna dintată, complet sigilată, diametru 1348 m, cu dantura cu duritate marita
2. Motor hidrostatic rotire lama mediana dotat cu sistem de protectie impotriva suprasarcinilor
3. Sistem de sprijinire a lamel mediane cu rulment axial
4. Indicator unghi articulatie
5. Sistem ce permite pozitia de plutire pentru cilindri ridicare lama
6. Aparatori de noroi la rotile din fata si spate
7. Trusa de scule, manual de operare
8. Protectie transmisie cardanica
9. Salopeta operator
10. Catalog piese de schimb

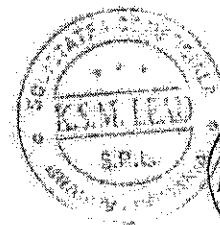

K.S.M.-Lead SRL
 Complex Scheidt, Calea Fagarasului nr. 59,
 Stand 69, Brasov, Romania
 RO 18481861, JO8/528/2006
 E-mail: office@ksm.ro
 Tel: +40 371 13.86.37
 Fax: +40 372 004 322 / +40 268 708 969



Pret CIP *

188.363,00 EURO

*** pretul este exprimat in EURO si nu contine TVA**

CONDITII COMERCIALE:

1. Plata si valabilitate oferta

Plata va fi efectuata la cursul BNR + 0,5% din ziua emiterii facturii fiscale;
 Plata se va efectua 25% inainte de livrare conform facturii proforme iar diferenta la livrare;
 In cazul finantarii prin leasing livrarea se va efectua dupa aprobarea dosarului de leasing si
 efectuarea platii avansului;
 Valabilitate oferta: 30 de zile

2. Locul, conditia si termenul de livrare

Locul de livrare : CIP client

Termen de livrare: STOC - oferta este valabila in limita stocului

3. Transport si instruirea personalului

Transportul si ambalarea sunt gratuite

Instruirea personalului este inclusa si gratuita.

Costul pentru transport este 0 RON

Costul pentru instruirea personalului este 0 RON

4. Stare produse si garantie, tehnologii folosite

Produsele sunt noi si nefolosite.

Garantia standard acordata este de 12 luni fara limita de ore de functionare .

5. Alte precizari

Interventile service au loc in locatia clientului sau in unitatile service agreeate doar in urma
 solicitarii scrise din partea clientului. Asiguram piese de schimb originale atat pentru perioada de
 garantie cat si postgarantie pentru minim 10 ani.

Cu stima,
 Marius Tudose



Model: Autogreder HBM Nobas BG1601A

% eur

Preț CIP (fără TVA) 188363

Avans: 20% 37.672,60

Val. Finanțată: 150.690,40

Val. Rezid. 1% 1.883,63

Perioada (luni): 60

Dobanda (p.a.): 5,79%

Tax management 1% 3.202,17

Comision gest. 0

Frecvența plăți 12 12 (pe/an)

Nr. Rata	Dobanda	Capital	Comision gestione contract	Rata leasing	VR	Balanta	TVA	Valoarea totala
Avans		37672,60	200,00			-150690,40	9041,42	50932,72
1	727,08	2144,35		2.871,43		-148546,05	689,14	3.560,57
2	716,73	2154,70		2.871,43		-146391,35	689,14	3.560,57
3	706,34	2165,09		2.871,43		-144226,26	689,14	3.560,57
4	695,89	2175,54		2.871,43		-142050,72	689,14	3.560,57
5	685,39	2186,04		2.871,43		-139864,68	689,14	3.560,57
6	674,85	2196,58		2.871,43		-137668,10	689,14	3.560,57
7	664,25	2207,18		2.871,43		-135460,92	689,14	3.560,57
8	653,60	2217,83		2.871,43		-133243,09	689,14	3.560,57
9	642,90	2228,53		2.871,43		-131014,56	689,14	3.560,57
10	632,15	2239,28		2.871,43		-128775,28	689,14	3.560,57
11	621,34	2250,09		2.871,43		-126525,19	689,14	3.560,57
12	610,48	2260,95		2.871,43		-124264,24	689,14	3.560,57
13	599,57	2271,86		2.871,43		-121992,38	689,14	3.560,57
14	588,61	2282,82		2.871,43		-119709,56	689,14	3.560,57
15	577,60	2293,83		2.871,43		-117415,73	689,14	3.560,57
16	566,53	2304,90		2.871,43		-115110,83	689,14	3.560,57
17	555,41	2316,02		2.871,43		-112794,81	689,14	3.560,57
18	544,23	2327,20		2.871,43		-110467,61	689,14	3.560,57
19	533,01	2338,42		2.871,43		-108129,19	689,14	3.560,57
20	521,72	2349,71		2.871,43		-105779,48	689,14	3.560,57
21	510,39	2361,04		2.871,43		-103418,44	689,14	3.560,57
22	498,99	2372,44		2.871,43		-101046,00	689,14	3.560,57
23	487,55	2383,88		2.871,43		-98662,12	689,14	3.560,57
24	476,04	2395,39		2.871,43		-96266,73	689,14	3.560,57
25	464,49	2406,94		2.871,43		-93859,79	689,14	3.560,57
26	452,87	2418,56		2.871,43		-91441,23	689,14	3.560,57
27	441,20	2430,23		2.871,43		-89011,00	689,14	3.560,57
28	429,48	2441,95		2.871,43		-86569,05	689,14	3.560,57
29	417,70	2453,73		2.871,43		-84115,32	689,14	3.560,57
30	405,86	2465,57		2.871,43		-81649,75	689,14	3.560,57
31	393,96	2477,47		2.871,43		-79172,28	689,14	3.560,57
32	382,01	2489,42		2.871,43		-76682,86	689,14	3.560,57
33	370,00	2501,44		2.871,43		-74181,42	689,14	3.560,57
34	357,93	2513,50		2.871,43		-71667,92	689,14	3.560,57

35	345,80	2525,63		2.871,43		-69142,29	689,14	3.560,57
36	333,61	2537,82		2.871,43		-66604,47	689,14	3.560,57
37	321,37	2550,06		2.871,43		-64054,41	689,14	3.560,57
38	309,06	2562,37		2.871,43		-61492,04	689,14	3.560,57
39	296,70	2574,73		2.871,43		-58917,31	689,14	3.560,57
40	284,28	2587,15		2.871,43		-56330,16	689,14	3.560,57
41	271,79	2599,64		2.871,43		-53730,52	689,14	3.560,57
42	259,25	2612,18		2.871,43		-51118,34	689,14	3.560,57
43	246,65	2624,78		2.871,43		-48493,56	689,14	3.560,57
44	233,98	2637,45		2.871,43		-45856,11	689,14	3.560,57
45	221,26	2650,17		2.871,43		-43205,94	689,14	3.560,57
46	208,47	2662,96		2.871,43		-40542,98	689,14	3.560,57
47	195,62	2675,81		2.871,43		-37867,17	689,14	3.560,57
48	182,71	2688,72		2.871,43		-35178,45	689,14	3.560,57
49	169,74	2701,69		2.871,43		-32476,76	689,14	3.560,57
50	156,70	2714,73		2.871,43		-29762,03	689,14	3.560,57
51	143,60	2727,83		2.871,43		-27034,20	689,14	3.560,57
52	130,44	2740,99		2.871,43		-24293,21	689,14	3.560,57
53	117,21	2754,22		2.871,43		-21538,99	689,14	3.560,57
54	103,93	2767,50		2.871,43		-18771,49	689,14	3.560,57
55	90,57	2780,86		2.871,43		-15990,63	689,14	3.560,57
56	77,15	2794,28		2.871,43		-13196,35	689,14	3.560,57
57	63,67	2807,76		2.871,43		-10388,59	689,14	3.560,57
58	50,12	2821,31		2.871,43		-7567,28	689,14	3.560,57
59	36,51	2834,92		2.871,43		-4732,36	689,14	3.560,57
60	22,83	2848,73		2.871,43	1.883,63		1141,25	3.560,57
Valoare reziduala		1.883,63						2335,70
Total valoare neta	237429,46	2887368,99		172205180				226902818

Model: Autogreder HBM Nobas BG160TA4

% eur

Preț CIP (fără TVA): 18836.3

Avans: 20% 37,672.60

Val. Eliberată: 150,690.40

Val. Rezid. 1% 1,883.63

Perioada (luni): 60

Dobanda (p.a.): 5.79%

Tax. management: 1.7% 3,202.17

Comision gest. 0

Frecvența plăți: 12 12 fact/an

Nr. Rata	Dobanda	Capital	Comision gestiune contract	Rata leasing	VR	Balanco	TVA	Total factura fără Casco
Avans		37672.60	200.00			-150690.40	9041.42	50932.72
1	727.08	2144.35		2,871.43		-148546.05	689.14	3,560.57
2	716.73	2154.70		2,871.43		-146391.35	689.14	3,560.57
3	706.34	2165.09		2,871.43		-144226.26	689.14	3,560.57
4	695.89	2175.54		2,871.43		-142050.72	689.14	3,560.57
5	685.39	2186.04		2,871.43		-139864.68	689.14	3,560.57
6	674.85	2196.58		2,871.43		-137668.10	689.14	3,560.57
7	664.25	2207.18		2,871.43		-135460.92	689.14	3,560.57
8	653.60	2217.83		2,871.43		-133243.09	689.14	3,560.57
9	642.90	2228.53		2,871.43		-131014.56	689.14	3,560.57
10	632.15	2239.28		2,871.43		-128775.28	689.14	3,560.57
11	621.34	2250.09		2,871.43		-126525.19	689.14	3,560.57
12	610.48	2260.95		2,871.43		-124264.24	689.14	3,560.57
13	599.57	2271.86		2,871.43		-121992.38	689.14	3,560.57
14	588.61	2282.82		2,871.43		-119709.56	689.14	3,560.57
15	577.60	2293.83		2,871.43		-117415.73	689.14	3,560.57
16	566.53	2304.90		2,871.43		-115110.83	689.14	3,560.57
17	555.41	2316.02		2,871.43		-112794.81	689.14	3,560.57
18	544.23	2327.20		2,871.43		-110467.61	689.14	3,560.57
19	533.01	2338.42		2,871.43		-108129.19	689.14	3,560.57
20	521.72	2349.71		2,871.43		-105779.48	689.14	3,560.57
21	510.39	2361.04		2,871.43		-103418.44	689.14	3,560.57
22	498.99	2372.44		2,871.43		-101046.00	689.14	3,560.57
23	487.55	2383.88		2,871.43		-98662.12	689.14	3,560.57
24	476.04	2395.39		2,871.43		-96266.73	689.14	3,560.57
25	464.49	2406.94		2,871.43		-93859.79	689.14	3,560.57
26	452.87	2418.56		2,871.43		-91441.23	689.14	3,560.57
27	441.20	2430.23		2,871.43		-89011.00	689.14	3,560.57
28	429.48	2441.95		2,871.43		-86569.05	689.14	3,560.57
29	417.70	2453.73		2,871.43		-84115.32	689.14	3,560.57
30	405.86	2465.57		2,871.43		-81649.75	689.14	3,560.57
31	393.96	2477.47		2,871.43		-79172.28	689.14	3,560.57

32	382.01	2489.42		2,871.43		-76682.86	689.14	3,560.57
33	370.00	2501.44		2,871.43		-74181.42	689.14	3,560.57
34	357.93	2513.50		2,871.43		-71667.92	689.14	3,560.57
35	345.80	2525.63		2,871.43		-69142.29	689.14	3,560.57
36	333.61	2537.82		2,871.43		-66604.47	689.14	3,560.57
37	321.37	2550.06		2,871.43		-64054.41	689.14	3,560.57
38	309.06	2562.37		2,871.43		-61492.04	689.14	3,560.57
39	296.70	2574.73		2,871.43		-58917.31	689.14	3,560.57
40	284.28	2587.15		2,871.43		-56330.16	689.14	3,560.57
41	271.79	2599.64		2,871.43		-53730.52	689.14	3,560.57
42	259.25	2612.18		2,871.43		-51118.34	689.14	3,560.57
43	246.65	2624.78		2,871.43		-48493.56	689.14	3,560.57
44	233.98	2637.45		2,871.43		-45856.11	689.14	3,560.57
45	221.26	2650.17		2,871.43		-43205.94	689.14	3,560.57
46	208.47	2662.96		2,871.43		-40542.98	689.14	3,560.57
47	195.62	2675.81		2,871.43		-37867.17	689.14	3,560.57
48	182.71	2688.72		2,871.43		-35178.45	689.14	3,560.57
49	169.74	2701.69		2,871.43		-32476.76	689.14	3,560.57
50	156.70	2714.73		2,871.43		-29762.03	689.14	3,560.57
51	143.60	2727.83		2,871.43		-27034.20	689.14	3,560.57
52	130.44	2740.99		2,871.43		-24293.21	689.14	3,560.57
53	117.21	2754.22		2,871.43		-21538.99	689.14	3,560.57
54	103.93	2767.50		2,871.43		-18771.49	689.14	3,560.57
55	90.57	2780.86		2,871.43		-15990.63	689.14	3,560.57
56	77.15	2794.28		2,871.43		-13196.35	689.14	3,560.57
57	63.67	2807.76		2,871.43		-10388.59	689.14	3,560.57
58	50.12	2821.31		2,871.43		-7567.28	689.14	3,560.57
59	36.51	2834.92		2,871.43		-4732.36	689.14	3,560.57
60	22.83	2848.73		2,871.43	1,883.63		1141.25	3,560.57
Valoare reziduala:		1,883.63						2,385.70
Total valoare neta:	23,479.16	189,366.00		172,285.86			1,141.25	206,902.01